



Electrolux

User Manual

500 Series Portable Blender

E5PB1-100L
E5PB1-100W
E5PB1-110L
E5PB1-110W

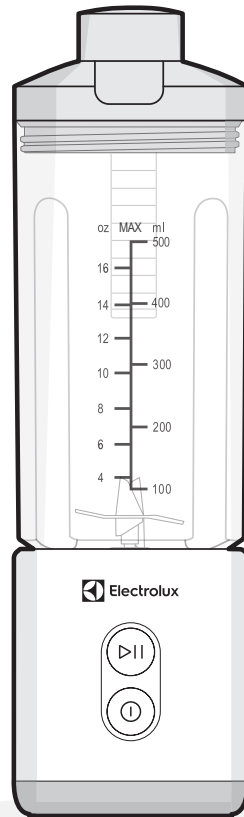

EN	User manual
CNT	説明書
TH	คู่มือแนะนำการใช้งาน
VN	Sách Hướng Dẫn
KR	사용 설명서

COMPONENT

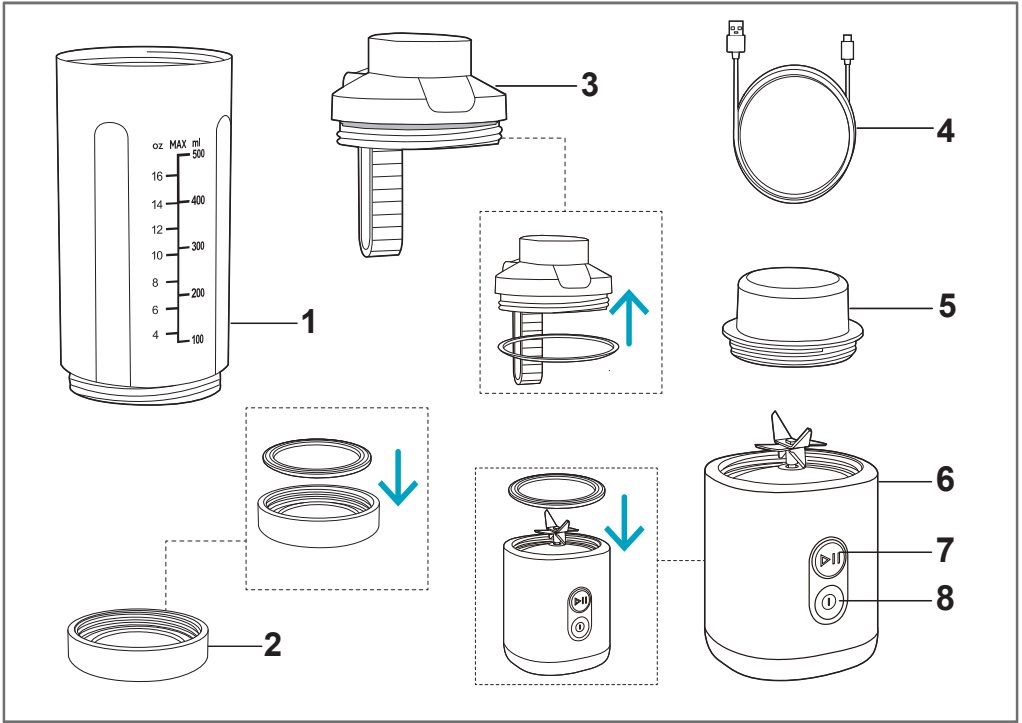

CLEAN AND CARE



OPERATING INSTRUCTIONS

1

100%
 Green light
 <20%
 Red light

≈2.5h
 100%

(Under the input of 5V 3A)

2

$>2\text{cm}$
 $\leq 2\text{cm}$
 $\leq 2\text{cm}$

3

4A

$>50^{\circ}\text{C}$
 Min 100ml

4B

Solid
 Soft

OR
 Max 500ml

5

6

30 sec

7

shake if stuck

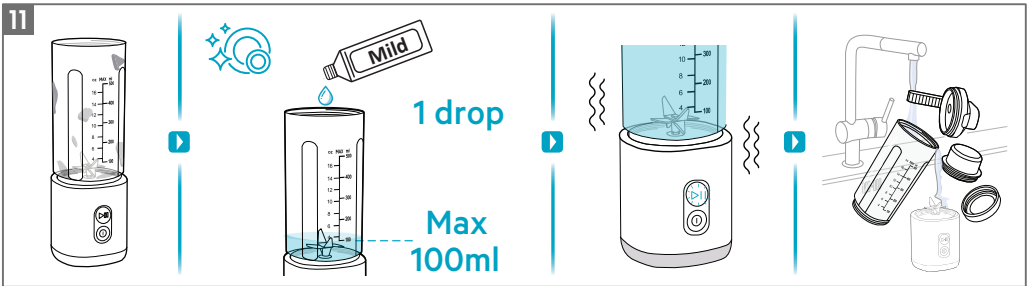
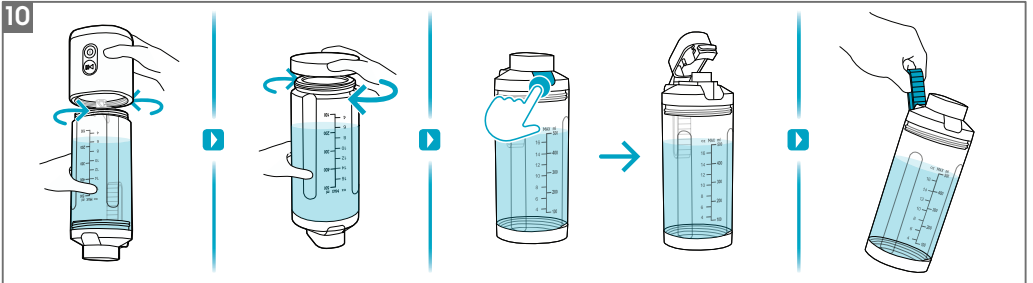
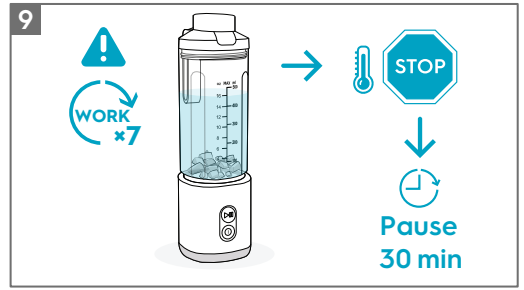
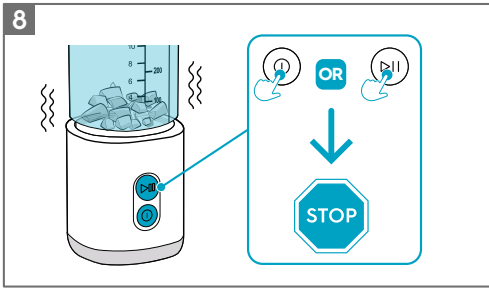

	Smoothie	350-400g milk 100g chopped banana	MAX 500ml	30 sec
	Watermelon Juice	50-100g 260g watermelon cubes	MAX 500ml	30 sec
	Protein Drink	1 300g 2 26g	MAX 300ml	30 sec

Replace the Battery

13

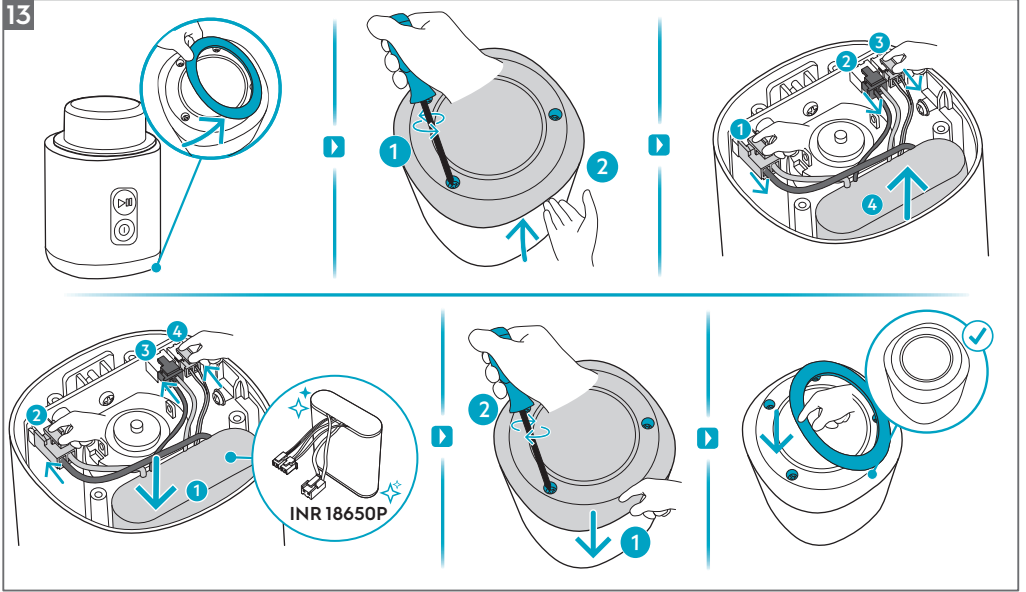

INSTRUCTION MANUAL

Graphics and drawings in this manual are solely for illustration purposes and are subject to variations from actual product.

Read all instructions carefully before using the appliance for the first time.

Keep this manual for future reference.

EN

CNT

TH

VN

KR

COMPONENTS

1. Blender jar
2. Jar cover (with sealing)
3. Sip lid with carry handle(with sealing)
4. Charging cable
5. Blade cover
6. Blender base(with sealing)
7. Start/Stop button
8. ON/OFF button

SAFETY ADVICE



Read the following instruction carefully before using the appliance for the first time.

- This appliance can be used by persons with reduced physical, sensory or mental capabilities or lack of experience and knowledge if they have been given supervision or instruction concerning use of the appliance in a safe way and if they understand the hazards involved. This appliance shall not be used by children. Keep the appliance and its cord out of reach of children. Cleaning and user maintenance shall not be made by children without supervision. Children shall not play with the appliance.
- Always place the appliance on a flat level surface.
- Always switch off and disconnect the appliance from the mains if it is left unattended and before assembling, disassembling, cleaning, changing accessories or approaching parts that move during use.
- **WARNING!** The blades are very sharp. Care shall be taken when assembling, disassembling after use or during cleaning.
- With heavy load (maximum capacity), do not let the blender run for more than 7 working cycles. Allow it to cool down for at least 30 minutes before continuing.
- Do not exceed the maximum filling volume as indicated on the jar.
- Never immerse the appliance body, cord or plug in water or any other liquid.
- Do not use this application to stir paint. It may cause an explosion.
- Do not let cord touch or hang over hot surfaces.
- Use only accessories or parts recommended for this appliance.
- Keep hands and utensils out of the appliance during operation to avoid the risk of severe injury or damage to the appliance.
- The blender jar cannot be used for blending or grinding hard and dry substances, except for ice cubes and frozen fruits.
- The blender jar is not suitable to blend hot liquid.
- **CAUTION:** In order to avoid a hazard due to inadvertent resetting of the thermal cut-out, this appliance must not be supplied through an external switching device, such as a timer, or connected to a circuit that is regularly switched on and off by the utility.
- **WARNING!** Potential injury may be caused from misuse.
- **WARNING!** Always operate the blender with the lid or the guard in position as indicated in the instructions.
- Never put a hand in the jar when it is placed on the base unit
- If food needs to be pushed down, use a suitable tool e.g. spatula.
- To ensure optimal freshness and flavor of food please consume food stored in the jar within 24 hours.
- Ensure that sealing rings are properly installed; otherwise, there is a risk of leakage.
- This appliance must only be supplied at safety extra low voltage corresponding to the marking on the appliance.

- Under abusive conditions, liquid may be ejected from the battery; avoid contact. If contact accidentally occurs, flush with water. If liquid contacts eyes, additionally seek medical help. Liquid ejected from the battery may cause irritation or burns.
- Do not expose a battery pack or tool to fire or excessive temperature. Exposure to fire or temperature above 100°C may cause explosion.
- This appliance contains batteries that are only replaceable by skilled persons.
- This appliance is intended to be used in household and similar applications such as:
 - personal on-the-go environments, like camping, sporting, traveling etc.
 - staff kitchen areas in shops, offices and other working environments;
 - farm houses;
 - by clients in hotels, motels and other residential type environments;
 - bed and breakfast type environments.

CLEAN AND CARE

1. Before using the appliance for the first time, remove and discard all packing material, bags, or tags attached to the appliance.
2. Jar, jar cover, sip lid with handle and blade cover are dishwasher safe. Clean the parts thoroughly. Make sure all the parts are completely dry before you start using the appliance.

Note: If the sealing rings are detached for cleaning, ensure they are correctly reinstalled before use, otherwise leakage may occur.
3. Rinse blender base under the tap water and wipe it with a damp cloth.

WARNING! Make sure the charging port is securely covered by silicone lid. The blades are very sharp. Handle carefully during cleaning.
4. Do not use abrasive cleaners, wire brush, steel, wooden & scouring pads or abrasive detergents (bleach etc) while cleaning the appliance.

OPERATION

1. It's a reminder to charge the appliance when an indicator of ON/OFF button turns red. After complete charging, the indicator turns green. The charging time is about 2.5 hours. (under the input of 5V,3A). The charging time will vary depending on the input.
2. Prepare the ingredients by rinsing them thoroughly and cut them into pieces no larger than 2cm size for best results and remove any hard or large seeds. Remove any thick peel from the fruit or vegetables.
3. Remove the blade cover from blender base, remove sip lid & jar cover from blender jar. Put the jar on the blender base and rotate it clockwise until it is securely locked into position.

WARNING! The appliance can't be turned on unless the jar is perfectly fitted on the blender base. Ensure that sealing ring is properly installed.
4. Adding COLD liquid up to at least 100ML, next add soft ingredients like fresh fruits, finish off with solid ingredients on the top like ice or frozen ingredients.

WARNING! Do not exceed the maximum filling volume as indicated on the jar.
5. Put the sip lid on the jar by rotate it clockwise.

WARNING! Never operate appliance without sip lid. Never run the blender empty, running the blender empty can cause overheating and can damage the product. Keep hands and utensils out of the blender jar while blending.

WARNING! During operation, do not remove your jar from blender base. If it's necessary to remove the jar, please turn off the appliance first then remove it.
6. Press ON/OFF button then the blender is on ready status, and the indicator is on. Press Start/Stop button to activate and the blender will operate until the program is finished.
7. One blending cycle is about 30 seconds. When the blender is stuck, shake it to help the blending.

8. Press any button to stop the blending whenever you want.
9. The blender could not be used if it runs for more than 7 blending cycles with heavy load (maximum capacity). Allow it to cool down for at least 30 minutes before continuing.
10. Button up the appliance and remove the blender base by turning it anticlockwise, cover the lid and turn the jar upside down. Press the button to open the cover and enjoy your drink.
11. Quick clean function: empty the jar and put it on the blender base. Fill it with water up to Max 100ML and one drop of mild detergent then cover the lid. Start with one working cycle then rinse all washable parts with warm water and wipe the blender base with damp cloth if needed.
NOTE: Wash the components right after use to avoid drying of food residue on components.
12. Recipes as below table.
13. Replace battery as below steps:
 - A. remove the silicone pad and 4 screws
 - B. remove the battery pack and replace new one
 - C. cover the lid and fix 4 screws and put the silicone pad back
 - D. check the appliance is workable or not

Recipe and maximum capacity

Recipe	Ingredients and maximum capacity	Recommended blending time
Smoothie	350-400g milk + 100g chopped banana (Max 500ml)	30sec
Watermelon Juice	50-100g water + 260g watermelon cubes (Max 500ml)	30sec
Protein Drink	300g water first + 26g powder (Max 300ml)	30sec

TROUBLESHOOTING

Problem	Possible Causes	Solutions
Blades stops in the middle of blending process.	Blade is stuck, due to the pieces of food are too large or too much food in jug.	Cut food into smaller pieces reduce some food or shake it to help the blending.
	Motor protector is automatically activated.	Wait for minimum 30 minutes, reduce some food, then restart.
Charging is taking longer than usual.	Room temperature is over 35°C.	Charging time will be longer if temperature is high, which is normal, store/charge product in a normal room temperature.

Problem	Possible Causes	Solutions
The indicator of ON/OFF button is flashing in red when CHARGING.	Battery Pack temperature is too high (~50°C)/low (~2°C). It is unable to charge the product.	Put appliance at ambient temperature condition, wait until temperature cools down/ raised up.
		Store/charge the product indoor and in room temperature between 5-35°C.
Press the on/off button, the yellow light flashes 3 times and then goes out.	The battery pack temperature exceeds 70°C, triggering the system protection	Rest for at least 30 minutes before restarting it
When charging, the product will not blend when pressing the Start/ Stop button.	The system settings cannot operate while charging.	Unplug the charging plug and wait for the indicator light to go out before using the appliance.
The appliance can operate, but the red light of ON/OFF button is always on.	The battery level is below 20%.	Charging is needed soon.
Suddenly it stops while operating and the red light of ON/OFF button remains on for 3 seconds when press buttons.	The battery is empty.	Charge the appliance immediately.
The indicator of ON/OFF button keeps flashing in red light	The battery pack is damaged.	Replace with new battery pack.
The indicator of ON/OFF button is flashing in red and green alternately.	The battery pack is damaged.	Replace with new battery pack.
Both indicators flash in red for 5 seconds simultaneously no matter which button you press.	The appliance has completed 7 working cycles.	Rest for 30 minutes before restarting.
To avoid battery damage when planning for long time storage without power connected.	The appliance and battery pack are planned to be stored and not in use for a long time.	To avoid battery damage, make sure to charge the battery pack to 0.5-1.5 hour before long-time storage. Once charged, keep it in a dry room with a room temperature of 10-25°C. Recharge it fully up to 10 hours after long time storage.

ENVIRONMENTAL CONCERNS

Recycle materials with the symbol . Put the packaging in relevant containers to recycle it. Help protect the environment and human health by recycling waste of electrical and electronic appliances.

Do not dispose appliances marked with the symbol  with the household waste. Return the product to your local recycling facility or contact your municipal office.



This symbol on the product and/or the battery pack indicate that it shall not be disposed as household waste. When the battery have been disposed of correctly, you have prevented the potential negative effect on the environment and human health which could be caused by inappropriate waste handling. The correct recycling will also have a positive impact on conserving natural resources in a sustainable way. The battery shall be removed for the product before disposal, the instruction for use will guide you how to remove the battery.

Hand over the battery to the appropriate collection point for the recycling of waste batteries. Your local authority or retailer can provide more info on where your nearest recycling facility is.

CUSTOMER CARE AND SERVICE

When contacting Service, ensure that you have the following data available: **Model, PNC, Serial Number**. The information can be found on the rating plate.

Due to the Electrolux policy of continual product development; specifications, colours, and details of our products and those mentioned in this manual are subject to change without notice.

EN

CNT

TH

VN

KR

說明手冊

本手冊中的圖片及插圖僅供說明指示用途，與實際產品可能存在差異。
首次使用本產品前，請仔細閱讀所有指示說明。
請保存本手冊以備將來參考之用。

組件

1. 攪拌隨行杯
2. 攪拌隨行杯底蓋（附密封圈）
3. 附提把飲口蓋（附密封圈）
4. 充電線
5. 刀片護蓋
6. 調理果汁機底座（附密封圈）
7. 開始 / 停止鍵
8. 開關鍵

安全建議



首次使用本產品前，請仔細閱讀以下所有指示說明。

- 本電器設計不適合體格、感官或精神能力不健全，或者是缺少經驗和知識的人士(包括兒童)使用，除非他們已透過負責他們安全的人士獲得有關使用本電器的監督或說明，並了解可能涉及的潛在風險。請勿讓孩童使用本產品。請將產品及其電源線放在孩童無法接觸之處。不得讓孩童在無人監督的情況下進行清潔或維護。請勿讓孩童將本產品當作玩具。
- 請務必將本產品放在平穩表面上。
- 本產品在無人看管時，或組裝、拆卸、清潔、更換配件或觸碰會轉動的零件前，請務必關閉本產品電源並斷開電源。
- 警告！刀片非常鋒利。組裝、使用後拆卸或清潔時請務必小心。
- 最大負荷（最大容量）時，請勿讓調理果汁機連續運轉超過 7 次攪拌循環。繼續使用前，請讓本產品冷卻至少 30 分鐘。
- 請勿超過攪拌杯上標明的最大裝填量。
- 切勿將本產品、電源線或插頭浸入水中或任何其他液體中。
- 請勿使用本產品攪拌油漆。這樣可能會引起爆炸。
- 請勿讓電源線接觸高溫表面或懸掛在高溫表面邊緣。
- 請勿使用建議以外的配件或零件。
- 運轉期間，請勿將手或器具放入本產品，以避免嚴重傷害或產品損壞。
- 除冰塊及冷凍水果外，請勿使用攪拌杯攪拌或研磨堅硬及乾燥物體。
- 攪拌杯不適合用於攪拌高溫液體。
- 注意：為防止溫度斷路器意外復位，請勿使用外部開關裝置對本產品供電（如計時器），或連接至由公共設施定期開關的線路。
- 警告！使用不當可能造成傷害。
- 警告！操作調理果汁機前，請務必依照使用說明將上蓋或防護裝置確實裝好。
- 攪拌杯放在底座上時，切勿將手伸入攪拌杯。
- 如需將食物往下推至刀片處，請使用刮刀等適當工具。
- 為確保食材的新鮮度與風味，請於 24 小時內將存放於攪拌杯中的食物食用完畢。
- 請確認密封圈是否安裝正確，否則可能造成滲漏。
- 請務必使用本產品標示之安全超低電壓供電。
- 使用不當時，可能導致液體從電池外洩，請避免接觸。如不慎接觸皮膚，請立即以清水沖洗。如不慎接觸眼睛，請立即以清水沖洗並尋求醫療協助。電池外洩的液體可能導致刺激或灼傷。
- 請勿讓電池組或工具暴露在火源或過高溫度中。暴露在火源或 100°C 以上的高溫中可能導致爆炸。
- 本產品內含電池，請務必由專業人員進行更換。
- 本產品僅供家庭與類似場景使用，如：
 - 個人移動場景，如露營、運動、旅行等。
 - 商店、辦公室和其他工作環境的員工廚房區域；
 - 農舍；
 - 飯店、汽車旅館和其他居家環境的住戶使用；
 - 小型旅館和民宿環境。

EN

CNT

TH

VN

KR

- 棄置本產品前必須先將電池取出（參考操作說明章節第13點）。
- 電池應以安全的方式棄置。
- 取出電池前電器應切斷電源。

清潔和保養

1. 首次使用本產品前，請拆除所有包裝材料、塑膠套或產品上的標籤後丟棄。
2. 攪拌隨行杯、底蓋、附提把飲口蓋和刀片護蓋皆可使用洗碗機清潔。請徹底清潔所有零件。開始使用本產品前，請確認所有零件是否已完全乾燥。
注意：若清潔時將密封圈拆下，使用前請務必確認有確實的安裝，否則可能發生漏水。
3. 請以清水沖洗調理果汁機底座外部，並以濕布擦拭清潔。
警告！沖洗時請確認充電孔已確實蓋緊矽膠蓋。
調理果汁機底座刀片非常鋒利。清潔時請務必小心。
4. 請勿使用研磨性清潔劑、鋼刷、菜瓜布及鋼絲絨，或含研磨成分的清潔劑（漂白水等）清潔本產品。

操作說明

1. 當開關鍵指示燈轉為紅色時，代表產品需要充電。充電完成後，指示燈會轉為綠色。充飽電力時間約為 2.5 小時（在5V,3A的輸入條件下）。實際充電時間依輸入電源而有所不同。
2. 將水果或蔬菜食材完全清洗乾淨後，去除粗厚表皮，切成不超過 2 公分的塊狀，並去除堅硬或較大的果核，以達到最佳攪拌效果。
3. 將刀片護蓋從調理果汁機底座取下，從攪拌杯取下底蓋與飲口蓋。將攪拌杯放在底座上，順時針旋轉以正確鎖固至定位。
警告！攪拌杯未正確安裝至調理果汁機底座上時，無法啟動本產品。使用前請確認調理果汁機底座的密封膠圈已正確安裝到位。
4. 倒入至少 100 毫升冷水，接著放入新鮮水果等較軟的食材，將冰塊或冷凍食材等較硬的食材放在最上面。
警告！請勿超過攪拌杯上所標示的最大裝填量。
5. 將飲口蓋放在攪拌杯上並順時針旋轉以蓋緊。
警告！請勿在未安裝飲口蓋的情況下操作本產品。請勿讓調理果汁機空轉，空轉可能導致過熱並損壞產品。攪拌時，雙手與器具應盡量遠離攪拌杯。
警告！產品運轉時，請勿將攪拌杯從底座上取下。如需取下攪拌杯，請關閉產品電源後再取下。
6. 按下開關鍵，調理果汁機即進入待機狀態，指示燈亮起。按下開始 / 停止鍵即可啟動，調理果汁機會運轉至程式結束。
7. 一次攪拌循環約為 30 秒。若調理果汁機卡住，請輕搖以協助攪拌。
8. 您可隨時按下任一按鍵停止攪拌。
9. 調理果汁機在最大負荷（最大容量）的情況下，連續運轉超過 7 次攪拌循環時，將無法繼續使用。再次開始使用前，請讓本產品冷卻至少 30 分鐘。
10. 將產品關閉、逆時針旋轉取下調理果汁機底座，蓋上底蓋順時針轉緊後，將攪拌杯倒置。輕壓開蓋鍵打開飲口蓋，即可享用您的飲料。
11. 快速清潔功能：清空攪拌杯後將其放在調理果汁機底座上。在攪拌杯裡注入清水（最多 100 毫升），加入一滴中性清潔劑後蓋上飲口蓋。啟動一次攪拌循環，接著用溫水沖洗所有可水洗零件；如有需要，可以濕布擦拭底座。
註：使用後請立即清洗零件，以免食物殘渣乾燥附著。
12. 食譜請參照下表。
13. 請依照以下步驟更換電池：
 - A. 取下矽膠墊與4顆螺絲，打開調理果汁機底座蓋子
 - B. 取下電池組並更換新的電池組
 - C. 蓋上蓋子、鎖上 4 顆螺絲後裝回矽膠墊
 - D. 確認產品是否可以正常運轉

食譜與最大容量建議

食譜	食材與最大容量	建議攪拌時間
香蕉奶昔	350-400g 牛奶 + 100g 切塊香蕉 (最多 500ml)	30 秒
西瓜汁	50-100g 水 + 260g 切塊西瓜 (最多 500ml)	30 秒
高蛋白飲品	先加入 300g 水，再加入 26g 高蛋白粉 (最多 300ml) *此為參考值，高蛋白水粉比例因品牌不同而異，請依使用品牌之建議比例調配	30 秒

故障排除

問題	可能的原因	解決方法
刀片在攪拌過程中停止運轉。	食材體積過大或攪拌杯中食材過多，造成刀片卡住。	將食材切成較小的塊狀、減少食材量或輕輕搖晃攪拌杯以幫助攪拌。
	馬達防護裝置自動啟動。	等待至少 30 分鐘並減少食材量，再重新啟動產品。
充電時間過長。	室溫超過 35°C。	高溫環境下充電時間會延長，屬於正常現象。請將產品存放於正常室溫中或於正常室溫下充電。
充電時，開關鍵指示燈會閃爍紅燈。	電池組溫度過高 (~50°C) / 過低 (~2°C)。無法為產品充電。	將產品置於環境溫度下，等待至溫度下降 / 上升。
		存放 / 充電產品時，請於室內溫度 5-35°C 的環境中進行。
按下開關鍵時，指示燈閃爍黃燈三次後熄滅。	電池組溫度超過 70°C，啟動系統保護功能。	靜置至少 30 分鐘後再重新啟動。
充電時，即使按下開始 / 停止鍵，產品亦不會運轉攪拌。	系統設定充電時無法運轉。	拔下充電插頭，等待指示燈熄滅後再使用產品。
產品可正常運轉，但開關鍵的指示紅燈持續亮起。	電量低於 20%。	請盡快為產品充電。
運轉時突然停止，按下開關鍵時指示紅燈亮起約 3 秒。	電池已耗盡。	請立刻將產品充電。
開關鍵指示燈持續閃爍紅燈。	電池組受損。	請更換新電池組。
開關鍵指示燈會紅綠燈交替閃爍。	電池組受損。	請更換新電池組。
無論按哪個按鈕，兩顆指示燈都同時亮起紅燈並閃爍 5 秒。	產品已完成 7 次工作循環。	將產品靜置 30 分鐘再重新啟動。
為避免電池在長時間存放且未通電的情況下受損	計畫因長時間不使用產品與電池組而將其存放	為避免電池損壞，請於長時間存放前將電池組充電 0.5-1.5 小時。充電後，將其存放在室溫 10-25°C 的乾燥室內。長期存放後，請於再次使用前完全充電 (最長達 10 小時)。

EN

CNT

TH

VN

KR

環境關懷

回收有標誌  的材料。請將包裝材料放到適當的容器中予以回收。回收電子和電氣器具廢棄物有利於保護環境及人類健康。

請勿將有標誌  的器具與家用廢棄物一同處理。請將產品送至當地回收廠或聯絡市政府辦公室。

 產品及/或電池組上此符號指的是不得以家用廢棄物處置。當電池經正確處理後，可防止因不當處理廢棄物而對環境和人體健康造成負面影響。正確的回收法以永續方式維護自然資源也將帶來正面影響。棄置前應從產品上將電池拆下，使用說明中提供拆除電池的方法。請將電池交給合適的廢棄電池回收站。關於離您最近的回收廠位置，可洽詢當地主管機關或零售商以獲得進一步資訊。

客戶服務

聯繫客服部門時，請確保您已掌握了以下資訊：**型號**、**PNC**、**製造號碼**。此類資訊可在產品機身標籤上找到。

由於Electrolux堅持永續開發的政策，本手冊之中提及的產品規格、顏色、詳細資訊等等均可能隨時更改，恕不另行通知。

有鑒於世界各國對綠色環保意識的重視，伊萊克斯依循 RoHS「危害性限制物質指令」誠實標示產品化學物質含量，關於本產品的 RoHS 聲明書，請上伊萊克斯官網 → 「服務與維修」 → 「通過歐盟 RoHS認證 - 了解更多」，依產品類別及型號檢索。

<https://www.electrolux.com.tw/support/rohs/>

คู่มือการใช้งาน

กราฟฟิกและภาพในคู่มือนี้มีไว้เพื่อเป็นภาพประกอบเท่านั้น และอาจแตกต่างจากผลิตภัณฑ์จริง อ่านคำแนะนำต่อไปอย่างละเอียดก่อนที่จะใช้งานเครื่องใช้ไฟฟ้าเป็นครั้งแรก โปรดเก็บคู่มือนี้ไว้ให้อ่านถึงในอนาคต

ส่วนประกอบ

1. โถปั่น
2. ฟาโถ (พร้อมวงยางซีล)
3. ฟาจับพร้อมมือที่จับ (พร้อมวงยางซีล)
4. สายชาร์จ
5. ที่ปิดใบมีด
6. ฐานเครื่องปั่น (พร้อมวงยางซีล)
7. ปุ่มเริ่ม/หยุด
8. ปุ่มเปิด/ปิด

คำแนะนำด้านความปลอดภัย



โปรดอ่านคำแนะนำต่อไปนี้อย่างถี่ถ้วนก่อนเริ่มใช้อุปกรณ์เป็นครั้งแรก

- บุคคลที่มีความสามารถทางร่างกาย ประสาทสัมผัสหรือจิตใจบกพร่องหรือขาดประสบการณ์และความรู้สามารถใช้อุปกรณ์นี้ได้หากพวกเขาได้รับการดูแลหรือคำแนะนำเกี่ยวกับการใช้อุปกรณ์อย่างปลอดภัยและหากเขาเข้าใจถึงอันตรายที่เกี่ยวข้อง ห้ามให้เด็กใช้งานอุปกรณ์นี้ เก็บอุปกรณ์และสายไฟให้พ้นมือเด็ก ห้ามเด็กทำความสะอาดและดูแลรักษาเครื่องหากไม่มีคนคอยดูแล เด็ก ๆ ไม่ควรเล่นกับอุปกรณ์
- วางอุปกรณ์บนพื้นเรียบเสมอ
- ปิดสวิตซ์และถอดปลั๊กอุปกรณ์ออกจากแหล่งจ่ายไฟเสมอเมื่อปล่อยทิ้งไว้โดยไม่ได้ใช้งาน และก่อนการประกอบ แยกชิ้นส่วน ทำความสะอาด เปลี่ยนอุปกรณ์เสริม หรือเข้าใกล้ส่วนที่มีการเคลื่อนไหวระหว่างการใช้งาน
- ค่าเตือน! ใบมีดมีความคมมาก ควรเอาใจใส่เวลาทำการประกอบหรือแยกชิ้นส่วนหลังการใช้งานหรือระหว่างทำความสะอาด
- เมื่อใช้งานเครื่องปั่นที่ความจุสูงสุด ไม่ควรใช้ต่อเนื่องเกิน 7 รอบการทำงาน ควรปล่อยให้เครื่อง หยุดพักเพื่อระบายความร้อนอย่างน้อย 30 นาที ก่อนใช้งานต่อ
- อย่าเติมเกินปริมาตรสูงสุดที่ระบุไว้บนโถ
- ห้ามจุ่มตัวอุปกรณ์ สายไฟ หรือปลั๊กลงในน้ำหรือของเหลวทุกชนิด
- อย่าใช้งานเครื่องนี้เพื่อคนสี อาจทำให้เกิดการระเบิดได้
- อย่าให้สายไฟสัมผัสหรือแขวนอยู่เหนือพื้นผิวร้อน
- ให้ใช้เฉพาะอุปกรณ์เสริมหรือชิ้นส่วนที่ได้รับการแนะนำสำหรับอุปกรณ์นี้เท่านั้น
- ห้ามเอามือหรือเครื่องมือทุกชนิดเข้าไปในอุปกรณ์ขณะใช้งาน เพื่อหลีกเลี่ยงความเสี่ยงต่อการบาดเจ็บรุนแรงหรือความเสียหายต่ออุปกรณ์
- โถปั่นไม่สามารถทำการปั่นหรือบดวัตถุแข็งและแห้งได้ ยกเว้นสำหรับก้อนน้ำแข็งและผลไม้แช่แข็ง
- โถปั่นไม่เหมาะสำหรับปั่นของเหลวร้อน
- ข้อควรระวัง: เพื่อหลีกเลี่ยงอันตรายจากการรีเซ็ตของตัวตัดความร้อนโดยไม่ตั้งใจ อุปกรณ์นี้ต้องไม่ถูกเชื่อมต่อผ่านอุปกรณ์สวิตซ์ภายนอก เช่นตัวจับเวลา หรือเชื่อมต่อกับวงจรที่มีการเปิด-ปิดเป็นประจำโดยผู้ให้บริการไฟฟ้า
- ค่าเตือน! การใช้งานผิดวิธีอาจทำให้เกิดการบาดเจ็บได้
- ค่าเตือน! ใช้เครื่องปั่นโดยใส่ฟาหรือที่กั้นตามตำแหน่งที่ระบุไว้ในคำแนะนำ
- ห้ามเอามือเข้าไปในโถขณะวางบนฐานอุปกรณ์
- ใช้เครื่องมือที่เหมาะสม เช่น ไม้พายทำอาหาร หากจำเป็นต้องกดอาหารลง
- เพื่อคงความสดใหม่และรสชาติของอาหารให้ดีที่สุด ควรบริโภคอาหารที่เก็บไว้ในภาชนะภายใน 24 ชั่วโมง
- ตรวจสอบให้แน่ใจวงยางซีลติดตั้งอย่างถูกต้อง มิฉะนั้นอาจเกิดการรั่วไหลได้
- เพื่อความปลอดภัย อุปกรณ์นี้ต้องใช้แรงดันไฟฟ้าค่าเป็นพิเศษตามที่ระบุไว้บนอุปกรณ์เท่านั้น
- หลีกเลี่ยงการสัมผัสของเหลวที่พุ่งออกจากเบตเตอร์ในสถานะการใช้งานที่รุนแรง ล้างด้วยน้ำทันทีหากสัมผัสโดยไม่ตั้งใจ ควรไปพบแพทย์ด้วย หากของเหลวนั้นเข้าตา
- อย่าให้ชุดเบตเตอร์หรือเครื่องมือสัมผัสกับไฟหรืออยู่ในที่อุณหภูมิสูงเกินไป การสัมผัสกับไฟหรืออยู่ในที่อุณหภูมิสูงเกินไปอาจทำให้เกิดการระเบิดได้

- อุปกรณ์ประกอบไปด้วยแบตเตอรี่ที่สามารถเปลี่ยนได้โดยผู้มีความชำนาญเท่านั้น
- ผลิตภัณฑ์ผลิตขึ้นเพื่อใช้ภายในบ้านและการใช้งานที่คล้าย ๆ กัน เช่น:
 - สภาพแวดล้อมส่วนบุคคลระหว่างการเดินทาง เช่น การตั้งแคมป์ เล่นกีฬา ท่องเที่ยว เป็นต้น
 - ส่วนที่กันเป็นครัวสำหรับพนักงานภายในร้าน สำนักงานและสถานที่ทำงานอื่น ๆ
 - ฟาร์มเฮาส์
 - ลูกค้าในโรงแรม หอพักและที่พักอาศัยประเภทอื่น
 - โรงแรมพร้อมเสิร์ฟอาหารเช้า

การทำความสะดวกและการดูแลรักษา

1. ก่อนใช้งานอุปกรณ์เป็นครั้งแรก ถอดและทิ้งวัสดุบรรจุภัณฑ์ ถุง หรือป้ายทั้งหมดที่ติดกับอุปกรณ์
2. โถ ฝาโถ ฝาจับพร้อมมือที่จับ และที่ปิดใบมีดสามารถล้างในเครื่องล้างจานได้
ทำความสะอาดชิ้นส่วนให้ทั่วถึง ตรวจสอบให้แน่ใจว่าชิ้นส่วนทั้งหมดแห้งสนิทก่อนเริ่มใช้อุปกรณ์
หมายเหตุ: หากถอดวงยางซีลออกเพื่อทำความสะอาด ให้ติดตั้งกลับให้ถูกต้องก่อนใช้งาน มิฉะนั้นอาจจะเกิดการรั่วไหลได้
3. หลังจากล้างทำความสะอาดฐานเครื่องปั่นด้วยน้ำแล้ว ให้ใช้ผ้าชุบน้ำหมาด ๆ เช็ดให้แห้งทุกครั้ง
คำเตือน! ตรวจสอบให้แน่ใจว่าช่องเสียบสายชาร์จปิดสนิทด้วยฝาซิลิโคนอย่างเรียบร้อย ห้ามจุ่มลงในน้ำหรือใช้น้ำฉีดล้างโดยเด็ดขาด!
4. อย่าใช้สารทำความสะอาดที่มีฤทธิ์กัดกร่อน แปรงลวด เหล็ก ไม้ แผ่นขัด หรือน้ำยาทำความสะอาดที่มีฤทธิ์กัดกร่อน (เช่น สารฟอกขาว ฯลฯ) ขณะทำความสะอาดอุปกรณ์

การดำเนินการ

1. เดือนให้ชาร์จอุปกรณ์เมื่อไฟแสดงสถานะของปุ่มเปิด/ปิดเปลี่ยนเป็นสีแดง ไฟแสดงสถานะจะเปลี่ยนเป็นสีเขียวหลังทำการชาร์จเสร็จ เวลาในการชาร์จประมาณ 2.5 ชั่วโมง (ภายใต้กำลังไฟขนาด 5V, 3A) ระยะเวลาในการชาร์จจะแตกต่างกันไปขึ้นอยู่กับไฟเข้า
2. เตรียมวัตถุดิบโดยล้างให้สะอาดอย่างทั่วถึง และหั่นเป็นชิ้นที่มีขนาดไม่เกิน 2 ซม. และให้นำเมล็ดที่แข็งหรือมีขนาดใหญ่ออกด้วยเพื่อให้ได้ผลลัพธ์ที่ดีที่สุด เอาเปลือกผลไม้หรือผักที่หนาออกให้หมด
3. ถอดที่ปิดใบมีดออกจากฐานเครื่องปั่น และถอดฝาจับกับฝาโถออกจากโถปั่น วางโถบนฐานเครื่องปั่นและหมุนตามเข็มนาฬิกาจนกว่าจะล็อกเข้าที่อย่างแน่นหนา
คำเตือน! ไม่สามารถเปิดเครื่องได้หากโถปั่นไม่ถูกใส่พอดีหนาแน่นกับฐานเครื่องปั่น วางโถบนฐานเครื่องปั่นและหมุนตามเข็มนาฬิกาจนกว่าจะล็อกเข้าที่อย่างแน่นหนา ตรวจสอบว่าซีลยางได้รับการติดตั้งอย่างถูกต้องและแน่นหนา
4. เติมน้ำเย็นจนจก อย่างน้อย 100 มล. ถัดไปจากนั้นใส่วัตถุดิบ เช่น ผลไม้สด แล้วค่อยใส่วัตถุดิบแข็งตาม เช่น น้ำแข็งหรือวัตถุดิบแข็ง
คำเตือน! อย่าเติมน้ำปริมาณสูงสุดที่ระบุไว้บนโถ
5. ปิดฝาจับบนโถโดยหมุนตามเข็มนาฬิกา
คำเตือน! ห้ามใช้งานอุปกรณ์โดยไม่มีฝาจับ ห้ามเปิดเครื่องปั่นโดยที่ไม่มีส่วนผสมอยู่ในโถ เพราะอาจทำให้เครื่องปั่นร้อนเกินไปและก่อให้เกิดความเสียหายต่อผลิตภัณฑ์ได้ ห้ามเอามือหรือเครื่องมือทุกชนิดเข้าไปในโถปั่นขณะทำการปั่น
คำเตือน! อย่าถอดโถออกจากฐานเครื่องปั่นขณะใช้งาน กรุณาปิดอุปกรณ์ก่อนแล้วจึงถอดโถออกหากมีความจำเป็นต้องถอดโถ
6. กดปุ่มเปิด/ปิด จากนั้นเครื่องปั่นจะอยู่ในสถานะพร้อมใช้งานและไฟแสดงสถานะจะแสดงขึ้น กดปุ่มเริ่ม/หยุดเพื่อเริ่มการทำงาน และเครื่องปั่นจะทำงานจนกระทั่งโปรแกรมเสร็จสิ้น
7. หนึ่งรอบการปั่นมีเวลาประมาณ 30 วินาที เขย่าโถเพื่อช่วยให้ปั่นต่อไปได้เมื่อเครื่องปั่นเกิดการติดขัด
8. กดปุ่มใดก็ได้เพื่อหยุดการปั่นเมื่อใดก็ตามที่คุณต้องการ
9. ไม่ควรใช้งานเครื่องปั่น หากมีการปั่นต่อเนื่องมากกว่า ประมาณ 7 รอบ ที่ความถี่สูงสุด ควรปล่อยให้เครื่อง พักและระบายความร้อนอย่างน้อย 30 นาที ก่อนเริ่มใช้งานต่อ
10. เมื่อเสร็จสิ้นการใช้งาน ปิดอุปกรณ์แล้วถอดฐานเครื่องปั่นโดยหมุนทวนเข็มนาฬิกา ปิดฝาและคว่ำโถลง กดปุ่มเพื่อเปิดฝาและต้มต้มน้ำกับเครื่องดื่มของคุณ
11. ฟังก์ชันทำความสะอาดตัวเอง: เอาของในโถออกแล้ววางโถบนฐานเครื่องปั่น เติมน้ำจนถึงระดับสูงสุด 100 มล. และใส่น้ำยาทำความสะอาดอ่อน ๆ หนึ่งหยด จากนั้นเปิดฝาโถให้เรียบร้อย เริ่มทำความสะอาดด้วยรอบการ

ทำงานหนึ่งรอบ จากนั้นล้างชิ้นส่วนที่ล้างได้ทั้งหมดด้วยน้ำอุ่น และเช็ดฐานเครื่องปั่นด้วยผ้าชุบน้ำหมาด ๆ ตามต้องการ

หมายเหตุ: ล้างชิ้นส่วนต่าง ๆ ทันทีหลังใช้งานเพื่อป้องกันคราบอาหารแห้งติดบนชิ้นส่วน

12. สูตรอาหารตามตารางด้านล่างนี้

13. เปลี่ยนแบตเตอรี่ตามขั้นตอนด้านล่างนี้:

- ถอดแผ่นซิลิโคนและสกรูทั้ง 4 ตัวออก
- ถอดชุดแบตเตอรี่เก่าออกแล้วใส่แบตเตอรี่ใหม่
- ปิดฝา ยึดสกรูทั้ง 4 ตัวแล้วใส่แผ่นซิลิโคนกลับคืน
- ตรวจสอบว่าสามารถใช้งานอุปกรณ์ได้ตามปกติหรือไม่

สูตรการผสมและปริมาณสูงสุดที่รองรับได้

สูตรอาหาร	ส่วนผสมที่ต้องใช้และปริมาณสูงสุดที่รองรับได้	เวลาการปั่นที่แนะนำ
สมูทตี้	นม 350-400 ก. + กล้วยหั่น 100 ก. (สูงสุด 500 มล.)	30 วินาที
น้ำแดงโม	น้ำ 50-100 ก. + แดงโมหั่นเต๋า 260 ก. (สูงสุด 500 มล.)	30 วินาที
เครื่องดื่มโปรตีน	ใส่น้ำ 300 ก. ก่อน จากนั้นใส่ผงโปรตีน 26 ก. (สูงสุด 300 มล.)	30 วินาที

ปัญหาและวิธีการแก้ไข

อาการผิดปกติ	สาเหตุที่เป็นไปได้	วิธีแก้ไข
ใบมีดหยุดทำงานขณะกำลังปั่น	ใบมีดติดขัด เนื่องจากชิ้นอาหารมีขนาดใหญ่เกินไปหรือใส่อาหารมากเกินไปในโถ	หั่นอาหารให้ชิ้นเล็กลง ลดปริมาณอาหารบางส่วน หรือเขย่าโถเพื่อช่วยในการปั่น
	ระบบป้องกันมอเตอร์จะทำงานโดยอัตโนมัติ	รออย่างน้อย 30 นาที ลดปริมาณอาหารบางส่วน แล้วเริ่มใช้งานใหม่
การชาร์จใช้เวลานานมากกว่าปกติ	อุณหภูมิห้องสูงกว่า 35°C	เวลาในการชาร์จจะนานขึ้นหากอุณหภูมิสูง ซึ่งเป็นเรื่องปกติ ให้เก็บ/ชาร์จผลิตรักข์ในอุณหภูมิห้องปกติ
ไฟแสดงสถานะที่ปุ่มเปิด/ปิดกระพริบสีแดงเมื่อทำการชาร์จ	อุณหภูมิของชุดแบตเตอรี่สูงเกินไป (~50°C)/ต่ำเกินไป (~2°C) ไม่สามารถชาร์จผลิตรักข์ได้	ให้วางอุปกรณ์ในสภาพอุณหภูมิห้อง รอจนกว่าอุณหภูมิจะเย็นลง/สูงขึ้น
		จัดเก็บ/ชาร์จผลิตรักข์ภายในห้องและห้องที่มีอุณหภูมิห้องระหว่าง 5-35°C

อาการผิดปกติ	สาเหตุที่เป็นไปได้	วิธีแก้ไข
กดปุ่มเปิด/ปิด ไฟลีเหลืองจะ กระพริบ 3 ครั้งแล้วดับลง	อุณหภูมิของชุดแบตเตอรี่เกิน 70°C จะทำให้ระบบการป้องกันเริ่มทำงาน	ให้พักอุปกรณ์อย่างน้อย 30 นาที ก่อนเริ่มใช้งานใหม่
ขณะทำการชาร์จ อุปกรณ์จะไม่ปับเมื่อกดปุ่มเริ่ม/ หยุด	ไม่สามารถใช้งานการตั้งค่าระบบขณะ ทำการชาร์จได้	ถอดปลั๊กชาร์จออกและรอจนไฟแสดง สถานะดับก่อนใช้งานอุปกรณ์
อุปกรณ์สามารถใช้งานได้ แต่ไฟสีแดงที่ปุ่มเปิด/ ปิดจะติดอยู่ตลอดเวลา	ระดับแบตเตอรี่ต่ำกว่า 20%	จำเป็นต้องชาร์จในเร็ว ๆ นี้
อุปกรณ์หยุดทำงานทันทีขณะ ใช้งาน และไฟสีแดงที่ปุ่มเปิด/ ปิดติดค้าง 3 วินาทีเมื่อกดปุ่ม	แบตเตอรี่หมด	ชาร์จอุปกรณ์ทันที
ไฟแสดงสถานะที่ปุ่มเปิด/ ปิดกระพริบสีแดงอย่างต่อเนื่อง	ชุดแบตเตอรี่ได้รับความเสียหาย	ให้เปลี่ยนชุดแบตเตอรี่ใหม่
ไฟแสดงสถานะที่ปุ่มเปิด/ ปิดกระพริบสีแดงและสีเขียว สลับกัน	ชุดแบตเตอรี่ได้รับความเสียหาย	ให้เปลี่ยนชุดแบตเตอรี่ใหม่
ไฟแสดงสถานะทั้งสองกระพริบ สีแดงพร้อมกันเป็นเวลา 5 วินาที ไม่ว่าจะกดปุ่มใดก็ตาม	อุปกรณ์ได้ทำงานครบ 7 รอบการ ทำงานแล้ว	ให้พักอุปกรณ์ 30 นาที ก่อนเริ่มใช้งาน ใหม่
เพื่อหลีกเลี่ยงความเสียหาย ของแบตเตอรี่เมื่อวางแผนจัด เก็บรักษาเป็นระยะเวลานาน โดยไม่มีการเชื่อมต่อกับแหล่ง จ่ายไฟ	อุปกรณ์และชุดแบตเตอรี่มีการ วางแผนจะให้จัดเก็บและไม่ได้ใช้งาน เป็นระยะเวลานาน	เพื่อหลีกเลี่ยงความเสียหายของ แบตเตอรี่ ตรวจสอบให้แน่ใจว่าได้ชาร์จ ชุดแบตเตอรี่ให้ถึง 0.5-1.5 ชั่วโมง ก่อน การเก็บรักษาเป็นระยะเวลานาน หลังจากได้รับการชาร์จแล้ว เก็บอุปกรณ์ ในห้องแห้งที่อุณหภูมิ 10-25°C ชาร์จ ใหม่จนเต็มถึง 10 ชั่วโมงหลังการเก็บ รักษาเป็นระยะเวลานาน

ข้อมูลเพื่อการรักษาสิ่งแวดล้อม

รีไซเคิลวัสดุที่มีสัญลักษณ์  ใส่บรรจุภัณฑ์ลงใน ภาชนะบรรจุที่เหมาะสมเพื่อนำไปรีไซเคิล ช่วยปกป้องสิ่งแวดล้อมและสุขภาพของมนุษย์ และเพื่อ รีไซเคิลขยะอุปกรณ์ไฟฟ้าและอิเล็กทรอนิกส์ อย่าง

ทั้งอุปกรณ์ที่มีเครื่องหมายสัญลักษณ์  ร่วมกับ ขยะในครัวเรือน ส่งคืนผลิตภัณฑ์ไปยังโรงงานรีไซเคิลในท้องถิ่น หรือติดต่อสำนักงานเทศบาลของคุณ

สัญลักษณ์  นี้บนผลิตภัณฑ์และ/หรือก่อนแบตเตอรี่บ่งบอกว่าจะต้องไม่ทิ้งสิ่งของนั้น ๆ ร่วมกับขยะทั่วไปในครัวเรือน เมื่อทำการกำจัดแบตเตอรี่อย่างถูกต้อง ถือว่าคุณได้ป้องกันผลกระทบต่อสิ่งแวดล้อมและสุขภาพของมนุษย์ซึ่งอาจมาจากการจัดการกับขยะที่ไม่เหมาะสมนั้นแล้ว การรีไซเคิลที่ถูกต้องจะส่งผลเชิงบวกเช่นกันต่อการอนุรักษ์ทรัพยากรธรรมชาติอย่างยั่งยืน ต้องถอดแบตเตอรี่สำหรับผลิตภัณฑ์ออกก่อนนำไปทิ้ง

ในการถอดแบตเตอรี่นั้นให้ปฏิบัติตามคำแนะนำในคู่มือใช้งาน ส่งมอบแบตเตอรี่ไปยังจุดเก็บรวบรวมแบตเตอรี่เสียที่เหมาะสมเพื่อนำไปรีไซเคิล สามารถขอข้อมูลเพิ่มเติมเกี่ยวกับศูนย์รีไซเคิลที่ใกล้ที่สุดจากหน่วยงานท้องถิ่นหรือผู้ค้าปลีกของคุณได้

การดูแลและบริการลูกค้า

เมื่อติดต่อศูนย์บริการลูกค้า ตรวจสอบให้แน่ใจว่าคุณมีข้อมูลต่อไปนี้พร้อมแล้ว: รุ่น, **PNC**, หมายเลขผลิตภัณฑ์ ซึ่งดูข้อมูลได้ที่ป้ายแสดงข้อมูลทางเทคนิค

เนื่องจากนโยบายการพัฒนาผลิตภัณฑ์ของอีเลคโทรลิกซ์ ข้อมูลทางเทคนิค สี และรายละเอียดต่าง ๆ ของผลิตภัณฑ์ รวมถึงข้อมูลต่าง ๆ ที่ระบุในคู่มือนี้ อาจมีการเปลี่ยนแปลงโดยไม่ต้องแจ้งให้ทราบล่วงหน้า

HƯỚNG DẪN SỬ DỤNG

Hình ảnh sử dụng trong hướng dẫn này chỉ mang tính chất minh họa và có thể khác so với sản phẩm thực tế.

Đọc kỹ tất cả các hướng dẫn trước khi sử dụng thiết bị lần đầu.

Vui lòng giữ lại hướng dẫn sử dụng này để tham khảo về sau.

CẤU TẠO

1. Cối xay
2. Nắp cối xay (với vòng đệm)
3. Nắp uồng trực tiếp có tay cầm (với vòng đệm)
4. Cáp sạc
5. Nắp lưỡi dao
6. Đế máy xay (với vòng đệm)
7. Nút Khởi động/Dừng
8. Nút BẬT/TẮT

LỜI KHUYÊN VỀ AN TOÀN



Đọc kỹ tất cả các hướng dẫn trước khi sử dụng thiết bị lần đầu.

- Thiết bị này có thể được sử dụng bởi những người bị suy giảm năng lực thể chất, tinh thần hoặc giác quan hoặc thiếu kinh nghiệm và kiến thức sử dụng, nếu họ được giám sát hoặc hướng dẫn cách sử dụng thiết bị một cách an toàn và nếu họ hiểu rõ các mối nguy hiểm liên quan. Trẻ em không được sử dụng thiết bị này. Để thiết bị và dây điện xa tầm tay trẻ em. Trẻ em không được thực hiện vệ sinh và bảo dưỡng thiết bị nếu không có sự giám sát. Không để trẻ em chơi với thiết bị.
- Luôn đặt thiết bị trên bề mặt phẳng.
- Luôn tắt và ngắt kết nối thiết bị khỏi nguồn điện nếu không có người trông coi và trước khi lắp ráp, tháo rời, vệ sinh, thay phụ kiện hoặc tiếp cận các bộ phận chuyển động trong quá trình sử dụng.
- **CẢNH BÁO!** Các lưỡi dao rất sắc. Cần cẩn thận khi lắp ráp, tháo rời sau khi sử dụng hoặc trong quá trình vệ sinh.
- Khi xay với tải nặng (dung tích tối đa), không để máy xay chạy quá 7 chu kỳ làm việc liên tiếp. Hãy để máy nghỉ và nguội ít nhất 30 phút trước khi tiếp tục sử dụng.
- Không được vượt quá lượng chứa tối đa được ghi trên cối xay.
- Không được nhúng thân thiết bị, dây nguồn hoặc phích cắm vào nước hay bất kỳ loại chất lỏng nào khác.
- Không sử dụng thiết bị này để khuấy sơn. Làm như vậy có thể gây nổ.
- Không để dây dẫn chạm hoặc treo trên bề mặt nóng.
- Chỉ sử dụng các phụ kiện hoặc bộ phận được khuyến nghị cho thiết bị này.
- Không được đưa tay và dụng cụ vào gần thiết bị trong khi vận hành để tránh nguy cơ bị thương nặng hoặc hư hỏng thiết bị.
- Cối xay không thể được sử dụng để xay hoặc nghiền các chất cứng và khô, ngoại trừ đá viên và trái cây đông lạnh.
- Cối xay không thích hợp để xay chất lỏng nóng.
- **CHÚ Ý:** Để tránh nguy hiểm do vô tình làm sai lệch cầu dao nhiệt, không được cấp nguồn thiết bị này thông qua thiết bị chuyển mạch bên ngoài, chẳng hạn như bộ hẹn giờ, hoặc được kết nối với mạch điện thường xuyên được bật và tắt bởi công ty điện lực.
- **CẢNH BÁO!** Có nguy cơ gây thương tích tiềm ẩn do sử dụng sai cách.
- **CẢNH BÁO!** Luôn đặt nắp hoặc tấm chắn ở đúng vị trí được chỉ dẫn trong hướng dẫn khi vận hành máy xay.
- Tuyệt đối không cho tay vào cối xay khi cối xay được đặt trên đế.
- Nếu cần ăn thức ăn xuống, hãy sử dụng dụng cụ phù hợp, ví dụ như thìa.
- Nhằm độ tươi ngon và hương vị của thực phẩm, vui lòng sử dụng hết thực phẩm được bảo quản trong bình trong vòng 24 giờ.
- Hãy đảm bảo rằng các vòng đệm được lắp đặt đúng cách; nếu không, nguy cơ rò rỉ có thể xảy ra.

EN

CNT

TH

VN

KR

- Thiết bị này chỉ được cấp nguồn ở điện áp cực thấp an toàn tương ứng với nhãn hiệu trên thiết bị.
- Trong điều kiện sử dụng quá mức, chất lỏng có thể bị bắn ra từ pin; tránh tiếp xúc. Nếu vô tình tiếp xúc, hãy rửa sạch bằng nước. Nếu chất lỏng tiếp xúc với mắt, hãy tìm kiếm sự trợ giúp y tế. Chất lỏng bắn ra từ pin có thể gây kích ứng hoặc bỏng.
- Không để pin hoặc dụng cụ tiếp xúc với lửa hoặc nhiệt độ quá cao. Tiếp xúc với lửa hoặc nhiệt độ trên 100°C có thể gây nổ.
- Thiết bị này chứa pin và chỉ những người có chuyên môn mới được thay thế.
- Thiết bị này được thiết kế để sử dụng trong hộ gia đình và các ứng dụng tương tự như:
 - môi trường cá nhân khi di chuyển, như cắm trại, chơi thể thao, du lịch, v.v.
 - Khu vực bếp của nhân viên trong các cửa hàng, văn phòng và các môi trường làm việc khác;
 - Trang trại;
 - Để khách hàng sử dụng trong khách sạn, nhà nghỉ và các môi trường cư trú khác;
 - Môi trường cung cấp chỗ nghỉ qua đêm có phục vụ bữa sáng.

VỆ SINH VÀ BẢO TRÌ

1. Trước khi sử dụng thiết bị lần đầu, hãy tháo và vứt bỏ tất cả vật liệu đóng gói, túi hoặc nhãn dán gắn trên thiết bị.
2. Cối xay, nắp cối xay, nắp uống trực tiếp có tay cầm và nắp lưới dao đều có thể rửa an toàn bằng máy rửa chén. Vệ sinh kỹ lưỡng các bộ phận. Đảm bảo tất cả các bộ phận đã khô hoàn toàn trước khi bắt đầu sử dụng thiết bị.
Lưu ý: Nếu các vòng đệm được tháo ra để vệ sinh, hãy đảm bảo lắp lại đúng vị trí trước khi sử dụng, nếu không có thể xảy ra rò rỉ.
3. Rửa phần đế máy xay dưới vòi nước và lau bằng khăn mềm.
CẢNH BÁO! Bảo đảm cổng sạc được đậy kín bằng nắp silicone.
Các lưỡi dao rất sắc. Cần thận khi vệ sinh.
4. Không sử dụng chất tẩy rửa mài mòn, bàn chải sắt, miếng thép, miếng gỗ, miếng cọ rửa hoặc chất tẩy rửa mài mòn (thuốc tẩy, v.v.) khi vệ sinh thiết bị.

VẬN HÀNH

1. Khi đèn báo nút BẬT/TẮT chuyển sang màu đỏ, thiết bị sẽ được nhắc nhở sạc. Sau khi sạc đầy, đèn báo sẽ chuyển sang màu xanh lá cây. Thời gian sạc khoảng 2,5 giờ (khi nguồn cấp điện dưới định mức 5V, 3A). Thời gian sạc sẽ thay đổi tùy thuộc vào thông số thực tế của nguồn cấp.
2. Chuẩn bị nguyên liệu bằng cách rửa sạch và cắt thành từng miếng có kích thước không quá 2 cm để có kết quả tốt nhất, đồng thời loại bỏ hạt cứng hoặc hạt to. Loại bỏ phần vỏ dày trên trái cây hoặc rau củ.
3. Tháo nắp lưới dao ra khỏi đế máy xay, mở nắp uống trực tiếp và nắp cối xay ra khỏi cối xay. Đặt cối xay lên đế máy xay và xoay theo chiều kim đồng hồ cho đến khi cối xay được khóa chặt vào vị trí.
CẢNH BÁO! Không thể bật thiết bị trừ khi cối xay được lắp vừa khít với đế máy xay. Bảo đảm vòng đệm (gioăng cao su) được lắp đúng vị trí trước khi xay.
4. Đổ chất lỏng LẠNH ít nhất 100 ML, sau đó thêm các nguyên liệu mềm như trái cây tươi, cuối cùng là các nguyên liệu rắn như đá hoặc nguyên liệu đông lạnh lên trên.
CẢNH BÁO! Không được vượt quá lượng chứa tối đa được ghi trên cối xay.
5. Đậy nắp uống trực tiếp bằng cách xoay theo chiều kim đồng hồ.
CẢNH BÁO! Không bao giờ vận hành máy xay khi không có nắp uống trực tiếp. Không bao giờ vận hành máy xay khi không có thức ăn, vì vận hành máy xay khi không có thức ăn có thể gây quá nhiệt và làm hỏng sản phẩm. Tránh để tay và dụng cụ tiếp xúc với cối xay trong khi xay.
CẢNH BÁO! Trong quá trình xay, không được tháo cối xay ra khỏi đế máy xay. Nếu cần tháo cối xay, vui lòng tắt máy trước rồi mới lấy ra.

6. Nhấn nút BẬT/TẮT, máy xay sẽ ở trạng thái sẵn sàng và đèn báo sáng. Nhấn nút Khởi động/ Dừng để kích hoạt và máy xay sẽ hoạt động cho đến khi chương trình hoàn tất.
7. Mỗi chu kỳ xay kéo dài khoảng 30 giây. Khi cối xay bị kẹt, hãy lắc cối xay để hỗ trợ xay.
8. Nhấn bất kỳ nút nào để dừng xay bất cứ khi nào bạn muốn.
9. Máy xay sẽ gặp rủi ro quá tải hoặc hư hỏng nếu chạy quá 7 chu kỳ liên tục với tải nặng (dung tích tối đa). Hãy để máy nguội ít nhất 30 phút trước khi tiếp tục.
10. Đóng kín máy và tháo đế máy xay bằng cách xoay ngược chiều kim đồng hồ, đẩy nắp và lật ngược cối xay. Nhấn nút để mở nắp và thường thức đồ uống của bạn.
11. Chức năng vệ sinh nhanh: đổ hết nguyên liệu trong cối xay và đặt lên đế máy xay. Đổ nước vào máy đến mức Tối đa 100 ML và một giọt chất tẩy rửa nhẹ, sau đó đẩy nắp lại. Bắt đầu với một chu trình làm việc, sau đó rửa sạch tất cả các bộ phận có thể rửa bằng nước ấm và lau đế máy xay bằng khăn ẩm nếu cần.
GHI CHÚ: Rửa sạch các bộ phận ngay sau khi sử dụng để tránh thức ăn thừa bám trên các bộ phận.
12. Công thức như bảng dưới đây.
13. Thay pin theo các bước sau:
 - A. tháo miếng đệm silicon và 4 ốc vít
 - B. tháo bộ pin và thay pin mới
 - C. đẩy nắp, vặn chặt 4 ốc vít và lắp miếng đệm silicon trở lại
 - D. kiểm tra xem thiết bị có hoạt động được không

Công thức và dung tích tối đa

Công thức	Nguyên liệu và dung tích tối đa	Thời gian xay khuyến nghị
Sinh tố	350-400 g sữa + 100 g chuối cắt nhỏ (Tối đa 500 ml)	30 giây
Nước ép dưa hấu	50-100 g nước + 260 g dưa hấu cắt hạt lựu (Tối đa 500 ml)	30 giây
Sinh tố Protein	300 g nước trước + 26 g bột (Tối đa 300 ml)	30 giây

XỬ LÝ SỰ CỐ

Vấn đề	Nguyên nhân có thể	Giải pháp
Lưỡi dao dừng giữa chừng trong quá trình xay.	Lưỡi dao bị kẹt do thức ăn quá to hoặc quá nhiều thức ăn trong cối xay.	Cắt thức ăn thành miếng nhỏ hơn, giảm bớt thức ăn hoặc lắc cối xay để hỗ trợ xay nhuyễn.
	Bộ phận bảo vệ động cơ sẽ tự động kích hoạt.	Chờ tối thiểu 30 phút, giảm bớt thức ăn, sau đó khởi động lại.
Thời gian sạc lâu hơn bình thường.	Nhiệt độ phòng trên 35°C.	Thời gian sạc sẽ lâu hơn nếu nhiệt độ cao, điều này là bình thường, hãy bảo quản/sạc sản phẩm ở nhiệt độ phòng bình thường.

Vấn đề	Nguyên nhân có thể	Giải pháp
Đèn báo nút BẬT/TẮT tiếp tục nhấp nháy màu đỏ khi ĐANG SẠC.	Nhiệt độ của Bộ pin quá cao (~50°C)/quá thấp (~2°C). Không thể sạc sản phẩm.	Đặt thiết bị ở điều kiện nhiệt độ môi trường, đợi cho đến khi nhiệt độ giảm xuống/tăng lên. Bảo quản/sạc sản phẩm trong nhà với nhiệt độ phòng từ 5-35°C.
Nhấn nút bật/tắt, đèn vàng nhấp nháy 3 lần rồi tắt.	Nhiệt độ bộ pin vượt quá 70°C, kích hoạt chế độ bảo vệ hệ thống	Nghỉ ít nhất 30 phút trước khi khởi động lại.
Khi đang sạc, sản phẩm sẽ không thể xay khi nhấn nút Khởi động/Dừng.	Các cài đặt hệ thống không thể hoạt động trong khi sạc.	Rút phích cắm sạc và đợi đèn báo tắt trước khi sử dụng thiết bị.
Thiết bị có thể hoạt động, nhưng đèn đỏ của nút BẬT/TẮT luôn sáng.	Mức pin dưới 20%.	Cần sạc ngay.
Thiết bị đột nhiên dừng khi đang hoạt động và đèn đỏ của nút BẬT/TẮT vẫn sáng trong 3 giây khi nhấn các nút.	Pin đã hết.	Sạc thiết bị ngay lập tức.
Đèn báo nút BẬT/TẮT tiếp tục nhấp nháy màu đỏ.	Bộ pin đã bị hỏng.	Thay bộ pin mới.
Đèn báo nút BẬT/TẮT nhấp nháy màu đỏ và xanh lá cây xen kẽ.	Bộ pin đã bị hỏng.	Thay bộ pin mới.
Cả hai đèn báo đều nhấp nháy màu đỏ trong 5 giây đồng thời bất kể bạn nhấn nút nào.	Thiết bị đã hoàn thành 7 chu kỳ làm việc.	Nghỉ 30 phút trước khi khởi động lại.
Để tránh làm hỏng pin khi dự định cất giữ lâu dài mà không kết nối nguồn điện.	Có ý định cất giữ và không sử dụng thiết bị và bộ pin trong thời gian dài.	Để tránh làm hỏng pin, hãy đảm bảo sạc bộ pin từ 0,5-1,5 giờ trước khi cất giữ lâu dài. Sau khi sạc đầy, bảo quản ở nơi khô ráo, nhiệt độ phòng từ 10-25°C. Sạc đầy trong tối đa 10 giờ sau thời gian dài bảo quản.

CÁC VẤN ĐỀ VỀ MÔI TRƯỜNG

Tái chế các vật liệu bằng ký hiệu . Để đồ đóng gói vào các thùng chứa có thể sử dụng để tái chế. Giúp bảo vệ môi trường và sức khỏe con người và tái chế phế liệu của các đồ dùng điện và điện tử.

Không vứt bỏ các đồ dùng có đánh dấu bằng ký hiệu  cùng với chất thải gia dụng. Gửi lại sản phẩm cho cơ sở tái chế ở địa phương của bạn hoặc liên hệ với văn phòng đô thị của bạn.

 Biểu tượng này trên sản phẩm và/hoặc bộ pin cho biết rằng không được thải bỏ sản phẩm và/hoặc bộ pin như rác thải sinh hoạt. Khi pin được thải bỏ đúng cách, bạn đã ngăn chặn được tác động tiêu cực tiềm ẩn đối với môi trường và sức khỏe con người có thể xảy ra do việc xử lý chất thải không phù hợp. Việc tái chế đúng cách cũng sẽ có tác động tích cực đến việc bảo tồn tài nguyên thiên nhiên một cách bền vững. Nên tháo pin khỏi sản phẩm trước khi thải bỏ, hướng dẫn sử dụng sẽ hướng dẫn bạn cách tháo pin.

Bàn giao pin cho điểm thu gom thích hợp để tái chế pin thải. Chính quyền địa phương hoặc nhà bán lẻ của bạn có thể cung cấp thêm thông tin về cơ sở tái chế gần bạn nhất.

CHĂM SÓC KHÁCH HÀNG VÀ DỊCH VỤ

Khi liên hệ với bộ phận Dịch vụ, hãy đảm bảo rằng bạn có sẵn các dữ liệu sau: **Kiểu thiết bị, PNC, Số Sêri**. Có thể tìm thấy thông tin trên nhãn thiết bị.

Theo chính sách liên tục phát triển sản phẩm của Electrolux; thông số kỹ thuật, màu sắc và chi tiết sản phẩm của chúng tôi và những thông tin đề cập trong hướng dẫn sử dụng này có thể thay đổi mà không cần thông báo.

사용 설명서

본 설명서의 그래픽 및 도면은 설명을 위한 예시일 뿐이며 실제 제품과 차이가 있을 수 있습니다. 기기를 처음 사용하기 전에 모든 설명을 주의 깊게 읽으십시오. 향후 참조하기 위해 본 설명서를 보관하십시오.

구성품

- | | |
|--------------------------------|----------------------|
| 1. 블렌더 용기 | 5. 칼날 커버 |
| 2. 용기 커버 (실리콘링 포함) | 6. 블렌더 베이스 (실리콘링 포함) |
| 3. 손잡이가 있는 휴대용 용기 뚜껑 (실리콘링 포함) | 7. 시작/정지 버튼 |
| 4. 충전 케이블 | 8. 켜기(ON)/끄기(OFF) 버튼 |

안전 주의사항



기기를 처음 사용하기 전에 다음과 같은 지침을 주의 깊게 읽으십시오

- 본 기기는 신체적, 감각적 또는 정신적 능력이 약하거나 경험과 지식이 부족한 사람이 안전한 방법으로 기기를 사용하도록 감독 또는 교육을 받고 관련 위험을 이해한 경우 사용할 수 있습니다. 이 기기는 어린이가 사용해서는 안 됩니다. 기기와 코드는 어린이의 손이 닿지 않는 곳에 보관하십시오. 및 사용자 유지보수는 어린이가 감독 없이 해서는 안 됩니다. 어린이가 이 제품을 가지고 놀지 못하게 해야 합니다.
- 항상 기기를 평평하고 수평이 맞은 표면에 놓으십시오.
- 사용하지 않을 때는 항상 전원을 끄고 전원 플러그를 뽑으십시오. 또한 조립, 분해, 청소, 액세서리 교체 또는 사용 중 움직이는 부품에 접근하기 전에 반드시 전원을 차단하십시오.
- 경고! 블레이드가 매우 날카롭습니다. 조립 시, 사용 후 분해 시 또는 청소 시 주의해야 합니다.
- 최대 용량으로 사용할 경우, 블렌더를 7회 연속 작동 이상 사용하지 마십시오. 과열을 방지하기 위해 최소 30분 이상 식힌 후 다시 사용하십시오.
- 용기에 표시된 최대 용량을 초과하여 채우지 마십시오.
- 본체, 코드 또는 플러그를 물이나 기타 액체에 절대 담그지 마십시오.
- 이 제품을 페인트를 저를 용도로 사용하지 마십시오. 폭발이 일어날 수 있습니다.
- 코드가 뜨거운 표면에 닿거나 매달리지 않도록 하십시오.
- 본 기기에 권장되는 액세서리나 부품만 사용하십시오.
- 작동 중에는 심각한 부상이나 기기 손상의 위험을 차단하기 위해 손과 도구를 기기 내부로 넣지 마십시오.
- 블렌더 용기는 얼음 조각과 냉동 과일을 제외하고 단단하고 건조한 물질을 갈거나 분쇄하는 데 사용할 수 없습니다.
- 블렌더 용기는 뜨거운 액체의 블렌딩에 적합하지 않습니다.
- 주의: 열 차단 장치의 우발적인 재설정으로 인한 위험을 피하기 위해 이 기기는 타이머와 같은 외부 스위칭 장치를 통해 전원을 공급받아서 안 되며, 전력회사에 의해 정기적으로 켜지고 꺼지는 회로에 연결해서도 안 됩니다.
- 경고! 오용으로 인해 부상을 입을 수 있습니다.
- 경고! 블렌더는 항상 뚜껑이나 보호대를 사용 설명서에 표시된 위치에 놓고 작동하십시오.
- 본체에 올려진 용기에 손을 넣지 마십시오.
- 음식을 돌려야 할 경우, 주걱과 같은 적절한 도구를 사용하십시오.
- 음식의 신선도와 풍미를 최적으로 유지하기 위해, 용기에 보관한 음식은 24시간 이내에 섭취해 주십시오.
- 실리콘링이 정확하게 장착되어 있는지 반드시 확인하십시오. 제대로 장착되지 않을 경우 누수의 위험이 있습니다.
- 본 기기는 기기에 표시된 안전 초저전압에서만 공급되어야 합니다.
- 부적절한 조건에서는 배터리에서 액체가 될 수 있으므로 만지지 마십시오. 실수로 만진 경우 물로 씻어내십시오. 액이 눈에 들어간 경우 즉시 의사의 진료를 받으십시오. 배터리에서 될 수 있는 액체는 자극이나 화상을 유발할 수 있습니다.
- 배터리 팩이나 도구를 불이나 과도한 온도에 노출시키지 마십시오. 불이나 100°C 이상의 온도에 노출되면 폭발할 수 있습니다.
- 이 기기에는 숙련된 기술자만 교체할 수 있는 배터리가 포함되어 있습니다.

- 이 기기는 다음과 같은 가정 및 유사한 용도로 사용하도록 설계되었습니다.
 - 캠핑, 스포츠, 여행 등 개인의 이동 환경
 - 상점, 사무실 및 기타 작업 환경의 직원 주방
 - 농가
 - 호텔, 모텔 및 기타 주거 환경의 고객
 - 민박(B&B) 환경.

청소 및 관리

1. 기기를 처음 사용하기 전에 기기에 부착된 포장재, 봉투 또는 태그를 모두 제거하고 버리십시오.
2. 용기, 용기 뚜껑, 손잡이가 있는 흡입 뚜껑, 블레이드 커버는 식기 세척기에 넣어도 됩니다. 부품을 철저히 청소하십시오. 기기를 사용하기 전에 모든 부품이 완전히 건조되었는지 확인하십시오.
참고: 세척을 위해 실리콘링을 분리한 경우, 사용 전에 반드시 올바르게 다시 장착해야 합니다. 그렇지 않으면 누수가 발생할 수 있습니다.
3. 블렌더 본체는 흐르는 물에 직접 행구지 마십시오. 젖은 천으로 닦아 청소해 주십시오.
경고! 충전 포트가 실리콘 덮개로 완전히 밀폐되어 있는지 확인하십시오.
블레이드가 매우 날카롭습니다. 세척 시 주의해서 다룹니다.
4. 기기 청소 중에는 연마성 세제, 와이어 브러시, 철제, 나무 수세미, 연마성 세제(표백제 등)를 사용하지 마십시오.

작동

1. ON/OFF 버튼 표시등이 빨간색으로 바뀌면 충전하라는 의미입니다. 충전이 완료되면 표시등이 녹색으로 바뀝니다. 충전 시간은 약 2.5시간입니다 (5V, 3A 입력 기준으로 충전되며). 입력 전원 사양에 따라 충전 시간은 달라질 수 있습니다.
2. 재료를 깨끗이 행군 후, 최상의 결과를 위해 2cm 이하 크기로 자르고 딱딱하거나 큰 씨앗은 제거하십시오. 과일이나 채소의 두꺼운 껍질은 제거하십시오.
3. 블렌더 베이스에서 블레이드 커버를 제거하고, 블렌더 용기에서 흡입 뚜껑과 용기 뚜껑을 분리합니다. 용기를 블렌더 베이스에 올려놓고 시계 방향으로 돌려 완전히 고정될 때까지 돌립니다.
경고! 용기가 블렌더 베이스에 완전하게 장착되지 않으면 기기가 작동하지 않습니다. 실링 링(밀폐 고무링)이 올바르게 장착되어 있는지 반드시 확인하십시오.
4. 최소 100ML의 액체 선까지 차가운 액체를 넣고, 신선한 과일 같은 부드러운 재료를 추가한 후, 얼음이나 냉동 재료 같은 단단한 재료를 맨 위에 올려 마무리합니다.
경고! 용기에 표시된 최대 용량을 초과하여 채우지 마십시오.
5. 흡입 뚜껑을 시계 방향으로 돌려 용기에 장착합니다.
경고! 흡입 뚜껑 없이 절대로 기기를 작동하지 마십시오. 절대 빈 상태로 블렌더를 작동하지 마십시오. 빈 상태로 작동하면 과열되어 제품이 손상될 수 있습니다. 블렌딩 중에는 손과 주방 도구를 용기 안으로 넣지 마십시오.
경고! 작동 중에는 용기를 블렌더 베이스에서 분리하지 마십시오. 용기를 분리해야 할 경우, 먼저 기기를 끈 후 분리하십시오.
6. ON/OFF 버튼을 누르면 블렌더가 준비 상태가 되어 표시등이 켜집니다. 시작/중지 버튼을 눌러 작동시키면 프로그램이 완료될 때까지 블렌더가 작동합니다.
7. 한 번의 블렌딩 주기는 약 30초입니다. 블렌더가 제대로 작동하지 않을 때는 흔들어 주십시오.
8. 원할 때마다 아무 버튼이나 눌러 블렌딩을 중단하십시오.
9. 무거운 재료(최대 용량)를 넣고 약 7회 이상 블렌딩 사이클을 연속으로 작동할 경우, 블렌더가 제대로 작동하지 않을 수 있습니다. 이 경우, 최소 30분 이상 식힌 후 다시 사용하시기 바랍니다.
10. 기기의 버튼을 누르고 블렌더 베이스를 시계 반대 방향으로 돌려 분리합니다. 뚜껑을 덮고 용기를 뒤집어 놓습니다. 버튼을 눌러 뚜껑을 열고 음료를 즐기세요.
11. 빠른 청소 기능: 용기를 비우고 블렌더 베이스에 올려놓습니다. 최대 100ML까지 물을 채우고 순한 세제 한 방울을 떨어뜨린 후 뚜껑을 덮습니다. 한 번의 작동으로 시작한 후 청소 가능한 모든 부품을 따뜻한 물로 행구고 필요한 경우 블렌더 베이스를 젖은 천으로 닦습니다.
참고: 사용 후 바로 부품을 세척하여 부품에 음식물 찌꺼기가 마르지 않도록 합니다.
12. 레시피는 아래 표를 참조하십시오.

13. 아래 단계에 따라 배터리를 교체합니다:

- A. 실리콘 패드와 나사 4개를 제거합니다
- B. 배터리 팩을 제거하고 새 배터리로 교체합니다
- C. 뚜껑을 덮고 나사 4개를 고정한 후 실리콘 패드를 다시 끼웁니다
- D. 기기 작동 여부를 확인합니다

레시피 및 최대 용량

레시피	재료 및 최대 용량	권장 블렌딩 시간
스무디	우유 350~400g + 다진 바나나 100g(최대 500ml)	30sec
수박 주스	물 50~100g + 수박 큐브 260g(최대 500ml)	30sec
단백질 음료	물 300g 먼저 + 분말 26g (최대 300ml)	30sec

문제 해결

일반적 문제점	가능한 원인	해결책
블렌딩 중간에 블레이드가 멈춥니다.	음식 조각이 너무 크거나 용기에 음식이 너무 많아 블레이드가 걸립니다.	음식을 더 작게 자르거나 양을 줄이거나 흔들어 블렌딩을 돕습니다.
	모터 보호 장치가 자동으로 작동합니다.	최소 30분 기다린 후 음식 양을 줄이고 다시 시작합니다.
충전 시간이 평소보다 길어집니다.	실내 온도가 35°C를 넘었습니다.	온도가 높으면 충전 시간이 길어지지만 이는 정상적인 현상이므로 제품을 일반 실내 온도에서 보관/충전합니다.
충전 중일때는 ON/OFF 버튼 표시등이 빨간색으로 깜빡입니다.	배터리 팩 온도가 너무 높거나 (~50°C) 낮습니다(~2°C). 제품을 충전할 수 없습니다.	기기를 주변 온도 조건에 두고, 온도가 내려가거나 올라갈 때까지 기다립니다.
		제품을 실내 및 5~35°C 사이의 실내에 보관/충전합니다.
ON/OFF 버튼을 누르면 노란색 표시등이 3번 깜박인 후 꺼집니다.	배터리 팩 온도가 70°C를 초과하면 시스템 보호 기능이 작동합니다.	최소 30분 동안 휴식을 취한 후 다시 시작합니다.
충전 중에는 시작/정지 버튼을 눌러도 제품이 작동하지 않습니다.	충전 중에는 시스템 설정을 사용할 수 없습니다.	충전 플러그를 뽑고 표시등이 꺼질 때까지 기다린 후 기기를 사용하십시오.
기기는 작동할 수 있으나, ON/OFF 버튼의 빨간 불이 항상 켜져 있습니다.	배터리 잔량이 20% 미만입니다.	곧 충전이 필요합니다.
작동 중 갑자기 멈추고, 버튼을 눌렀을 때 ON/OFF 버튼의 빨간 불이 3초 동안 켜져 있습니다.	배터리가 완전히 방전되었습니다.	즉시 기기를 충전하십시오.

일반적 문제점	가능한 원인	해결책
ON/OFF 버튼 표시등이 빨간색으로 계속 깜빡입니다.	배터리 팩이 손상되었습니다.	새 배터리 팩으로 교체하십시오.
ON/OFF 버튼 표시등이 빨간색과 녹색으로 번갈아 깜빡입니다.	배터리 팩이 손상되었습니다.	새 배터리 팩으로 교체하십시오.
어떤 버튼을 눌러도 두 표시등이 동시에 5초간 빨간색으로 깜빡입니다.	기기가 7회 작동 사이클을 완료했습니다.	30분 동안 작동을 멈춘 후 다시 시작합니다.
전원을 연결하지 않고 장시간 보관할 경우 배터리 손상을 방지할 수 있습니다.	기기와 배터리 팩은 장기간 사용하지 않고 보관할 예정입니다.	배터리가 손상되는 것을 방지하려면 장기간 보관하기 전에 배터리 팩을 0.5~1.5시간까지 충전합니다. 충전 후에는 10~25°C의 건조한 실내에 보관하십시오. 장시간 보관 후에는 최대 10시간 동안 완전히 충전하십시오.

환경 고려사항

기호 가 표시된 재료는 재활용하십시오. 포 장재는 해당 용기에 넣어 재활용하십시오. 전 기 제품 및 전자 제품 폐기물을 재활용하여 환 경과 인류 건강을 보호하십시오.

가정용 폐기 물 기호 가 표시된 제품을 폐기하지 마십시오. 가까운 재활용 시설에 제품을 보내거나 가까운 시청에 문의하십시오.

 제품 및/또는 배터리 팩에 표시된 이 기호는 가정용 쓰레기로 폐기해서는 안 됨을 나타냅니다. 배터리를 제대로 폐기하면 부적절한 폐기물 처리로 인해 발생할 수 있는 환경 및 인체 건강에 대한 잠재적인 부정적 영향을 예방할 수 있습니다. 올바른 재활용은 지속 가능한 방식으로 천연 자원을 보존하는 데에도 긍정적인 영향을 미칩니다. 제품을 폐기하기 전에 배터리를 제거해야 하며, 사용 설명서에 배터리 제거 방법이 설명되어 있습니다.

폐배터리 재활용을 위해 적절한 수거 장소에 배터리를 버려야 합니다. 가까운 재활용 시설의 위치는 지역 당국이나 소매업체에서 자세한 안내를 제공할 수 있습니다.

고객 관리 및 서비스

공인 서비스 센터에 문의할 때 사용할 수 있는지 확인할 데이터: **모델, PNC, 일련 번호**. 정보는 명판에서 확인할 수 있습니다.

Electrolux는 지속적인 제품 개발 정책에 따라 제품의 사양, 색상 및 세부 정보와 본 설명서에 언급된 내용은 예고 없이 변경될 수 있습니다.

中国

伊莱克斯 (中国) 电器有限公司
上海市虹口区公平路168号
北外滩来福士广场办公楼30层
售后服务: +86 9510 5801
网站: www.electrolux.com.cn

台湾

新加坡商伊莱克斯股份有限公司 台湾分公司
105408 台北市松山区敦化南路一段3號4樓
免付費客服專線: 0800-888-259
電子信箱: service.tw@electrolux.com
網站: www.electrolux.com.tw

KOREA

Electrolux Korea limited
22F, Youngpoong Building, 41,
Cheonggyecheon-ro, Jongno-gu,
Seoul, Republic of Korea (03188)
Tel : +82 2 6020-2200
Fax: +82 2 6020-2271-3
Customer Care Services : +82 1566-1238
Email : homecare.krh@electrolux.com
Website: www.electrolux.co.kr

INDONESIA

PT. Electrolux Indonesia
Jalan Tanah Abang II No. 42,
Petojo Selatan, Gambir,
Jakarta Pusat 10160,
Indonesia
Tel: +62 21 5081 7303
Fax: +62 21 5081 8069
SMS/WA : 0811-8339-777
Customer Care Services: 0804111 9999
Email: customercare@electrolux.co.id
Website: www.electrolux.co.id

PHILIPPINES

Electrolux Philippines, Inc.
12th Floor, Cyber Sigma Building
Lawton Avenue, Mckinley West, Fort Bonifacio
Taguig City, Philippines 1634
Domestic Toll Free: 1-800-10-845-CARE (2273)
Customer Care Services: (02) 845-CARE (2273) /
(02)-8845-4663
Email: wecare@electrolux.com
Website: www.electrolux.com.ph

THAILAND

Electrolux Thailand Co Ltd
Electrolux Building
1910 New Petchburi Road
Bangkapi, Huay Kwang
Bangkok 10310
Thailand
Tel: +66 2 725 9100
Fax: +66 2 725 9299
Customer Care Services: +66 2 725 9000
Email: customercarethai@electrolux.com
Website: www.electrolux.co.th

VIETNAM

Electrolux Vietnam Ltd
Floor 10, Sofic Tower, 10 Mai Chi Tho,
Thu Thiem Ward,
Thu Duc City
Ho Chi Minh City
Vietnam
Tel: +84 8 3910 5465
Fax: +84 8 3910 5470
Customer Care Services: 1800-58-8899
Email: vncare@electrolux.com
Website: www.electrolux.vn

MALAYSIA

Electrolux Home Appliances Sdn Bhd
Lot C6, No. 28, Jalan 15/22,
Taman Perindustrian Tiong Nam,
40200 Shah Alam, Selangor
Malaysia
Customer Careline: 1300-88-1122
Email: malaysia.customercare@electrolux.com
Website: www.electrolux.com.my

SINGAPORE

Electrolux SEA Pte Ltd
351 Braddell Road #01-04
Singapore 579713
Customer Care Services: +65 6727 3699
Email: customer-care.sin@electrolux.com
Website: www.electrolux.com.sg

UAE

ELECTROLUX APPLIANCES
MIDDLE EAST DMCC,
P.O.BOX 336148, Unit No. 4001,
MAZAYA BUSINESS AVENUE BBI,
JUMEIRAH LAKE TOWERS, Dubai,
United Arab Emirates

